

ThinLINE TLH250-9



Operation & Maintenance Manual

Keep For Your Records

LEADING PROVIDER OF BOLT LOADING & REMOVAL SOLUTIONS

ThinLINE TLH250-9

Contents

Unpacking.....	3
Introduction	3
Safety Tips	4
Power Requirements.....	5
Parts List.....	6 - 7

Assembly

Section 1 - Standard Flanges.....	8 - 9
Section 2 - Non-Standard Flanges.....	10 - 11

Operation

Tightening.....	12
Loosening	12
Pressure vs. Torque Chart	13
Maximum Suggested Make-up Torque Chart.....	14
Troubleshooting	14
Storage.....	15
ThinLINE Wrench Models.....	15
Limited Warranty	16

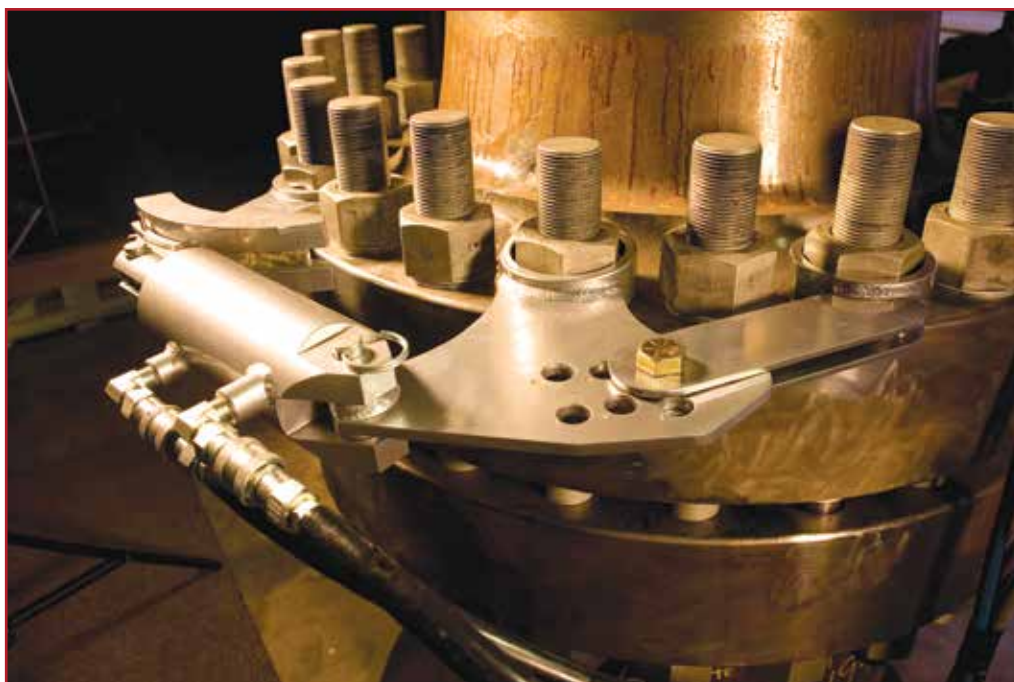

Read this manual carefully.

Unpacking

The ThinLINE wrench is fully tested before it is shipped. Upon receiving your wrench, verify that you have received the following items (see Figure 1):

- Semi-Ratchet wrench head (1)
- Reaction plate (2)
- Reaction leg (3)
- Hydraulic cylinder (4)
- Bolt (5)

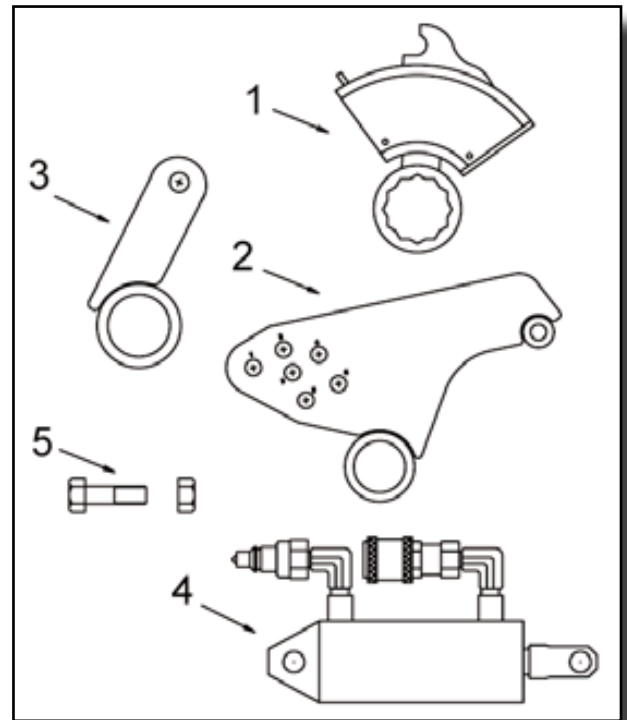

Figure 1

Introduction

You have chosen the finest hydraulic torque wrench on the market. ThinLINE wrenches are dependable and durable. When operated properly, these wrenches deliver accurate torque output within their specified range.

ThinLINE wrenches apply torque as the cylinder is extending. Figure 2 shows the wrench in operation.

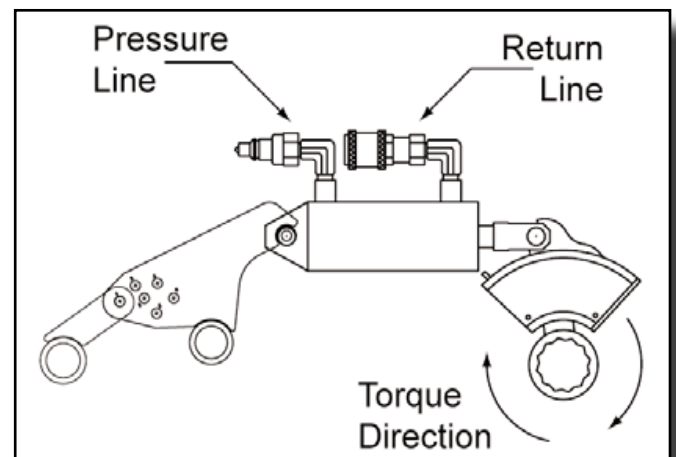

Figure 2



Safety Tips

- Always wear the appropriate safety equipment when operating this wrench; such as safety goggles or safety glasses and protective gloves.
- Do not allow the hydraulic hose to kink, twist, curl or bend so tightly that the oil flow within the hose is blocked or reduced. Never attempt to grasp a pressurized leaking hose with your hands.
- Never exceed the rated pressure of the wrench.
- Do not place your hands between the wrench and the reaction point.
- Use the torque values specified by your equipment manufacturer whenever it is available. For your convenience a chart of torque values for common size studs is included (page 14). This chart should not be used for any other type of stud as improper loading of the studs may cause damage to your equipment.
- Read and follow all instructions to avoid the risk of personal injury and/or property damage.

Power Requirements

ThinLINE wrenches are hydraulically driven. They require a hydraulic pump unit that can deliver at least 5,500 psi of hydraulic pressure.

The hydraulic pump can be driven by an air motor or an electric motor. FASTORQ carries a wide range of power pumps that can be used with ThinLINE wrenches. See Table 1 below.

Model Number	Motor Type	Maximum Operating Pressure
610A	Air	10,000 psi
205A	Air	10,000 psi
210E	Electric	10,000 psi
215E	Electric	10,000 psi

Table 1

FASTORQ power units include the necessary fittings and hoses. For complete information on these units, contact FASTORQ at 281-449-6466 or 800-231-1075 or visit us online at www.fastorq.com.



610A Power Unit

For best speed and performance we recommend powering ThinLINE wrenches with an FASTORQ 600 Series Power Unit. Model 610A (shown) operates up to ten times faster than traditional torque wrench power units.

Parts List Series 250-9 Reaction Units

Item #	Part #	Description
TLH215-9		
1	TLH215-9P	TLH215-9 Reaction Plate
2	TLH215-9L	TLH215-9 Reaction Leg
3	HHCS12-28-GR8	Hex Bolt, 3/4" x 1-3/4" Long Grade 8
4	NT12-SS	3/4" Nut, S.S.
5	TLH215-9H	TLH215-9 Wrench Head
TLH302-9		
1	TLH302-9P	TLH302-9 Reaction Plate
2	TLH302-9L	TLH302-9 Reaction Leg
3	HHCS12-28-GR8	Hex Bolt, 3/4" x 1-3/4" Long Grade 8
4	NT12-SS	3/4" Nut, S.S.
5	TLH302-9H	TLH302-9 Wrench Head
TLH308-9		
1	TLH308-9P	TLH308-9 Reaction Plate
2	TLH308-9L	TLH308-9 Reaction Leg
3	HHCS12-28-GR8	Hex Bolt, 3/4" x 1-3/4" Long Grade 8
4	NT12-SS	3/4" Nut, S.S.
5	TLH308-9H	TLH308-9 Wrench Head

Table 2

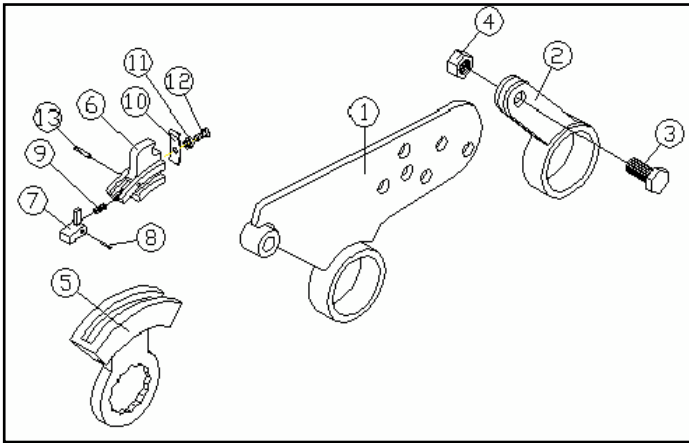

Figure 3

Parts List Series 250-9 Pawl Carrier Assembly

Item #	Part #	Description
6	B87099	9" ThinLINE Pawl Carrier
7	L84212	9" ThinLINE Pawl
8	RP2-12	1/8" x 3/4" Roll Pin
9	13B020GE/S	Pawl Spring, 6", 9" & 12" ThinLINE
10	L81225	Clevis Spring, 6", 9" & 12" ThinLINE
11	HHCS4-8-SS	1/4" x 1/2" Socket Head Cap Screw
12	LW4-SS	1/4" Lock Washer
13	RP2.5-16	5/32" X 1" Roll Pin

Table 3

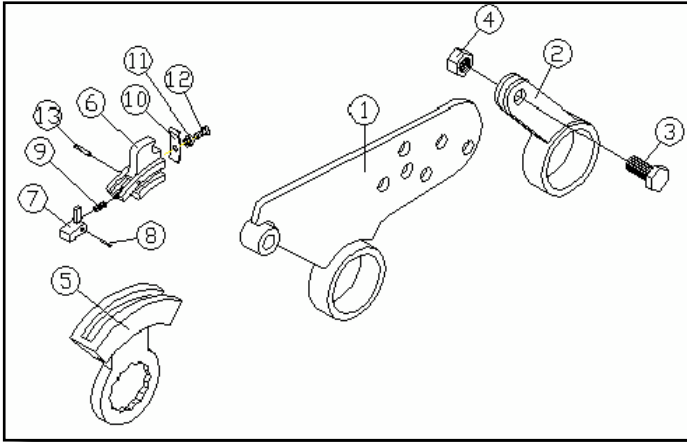

Figure 3

Parts List Series 250-9 Cylinder and Parts

Item #	Part #	Description
14	Series 250-9 Cylinder	
15	B90008	Clevis
16	A96110	Clevis Pin
17	ESR-0.500	1/2" Retaining Snap Ring
18	SP12-48	3/4" x 3" Speed Pin
Not Shown	HCSK250	Seal Kit (not shown, internal)

Table 4

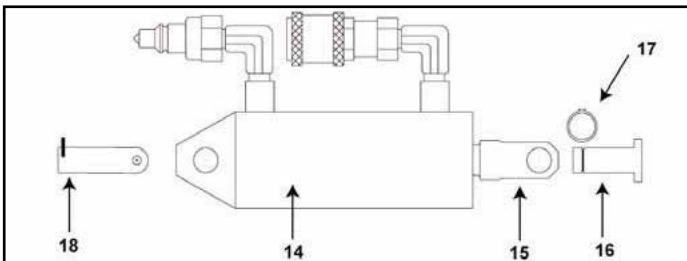

Figure 4

Section 1 - Standard Flanges Assembly

1. Select the correct ThinLINE wrench and reaction unit for the corresponding nut size.
2. Identify the bolt pattern as an API or ANSI standard.
3. Use the layouts supplied with this manual for the appropriate flange designation.

Figure 5 is a SAMPLE LAYOUT.

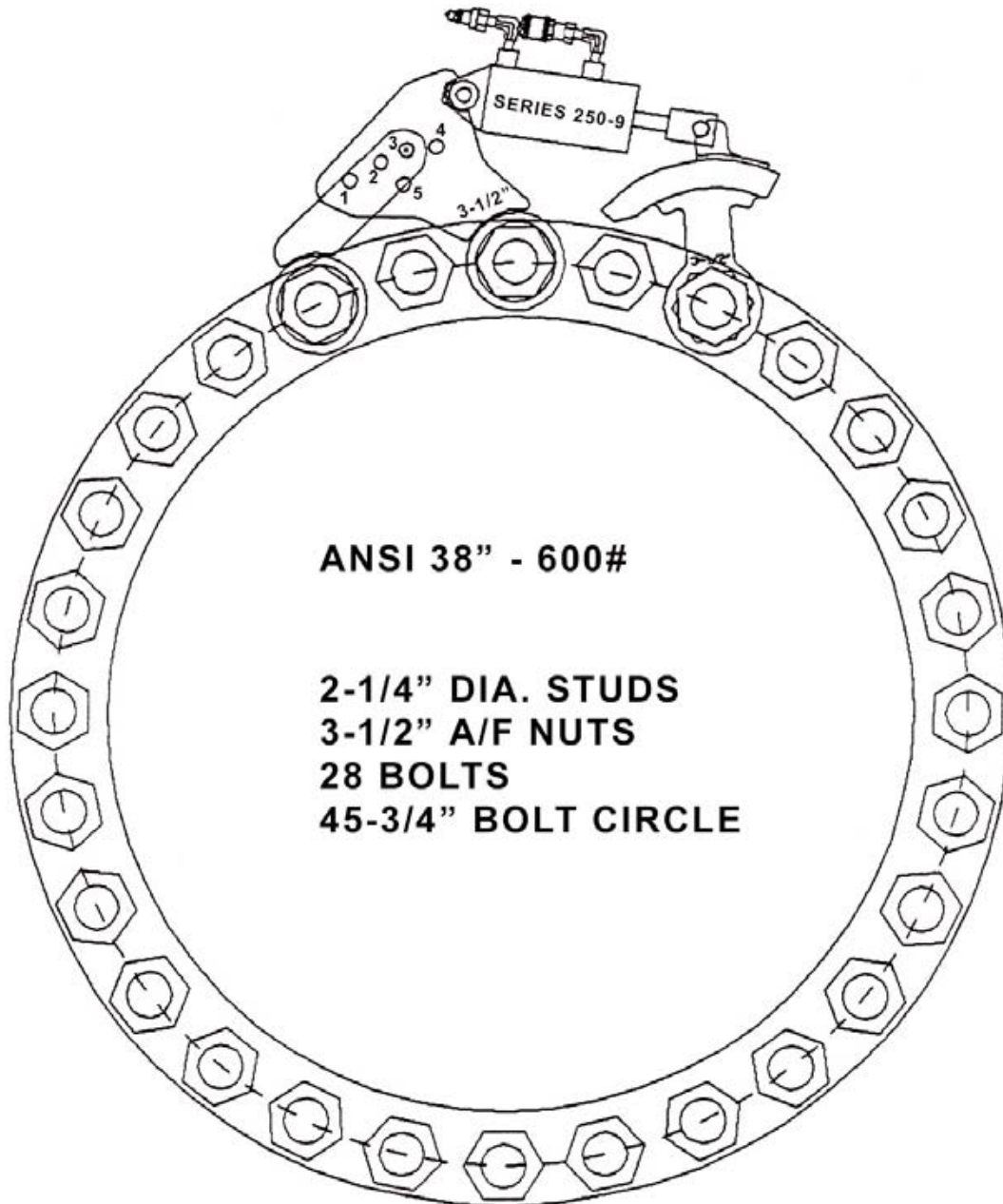

Figure 5

Section 1 cont.

4. Refer to Figure 6 during assembly.
5. Insert the bolt (5) through the hole in the reaction leg (4) and the corresponding hole in the reaction plate (3) as shown in the layout (figure 4 is a sample layout) for that flange and tighten the nut (6).
6. Insert the pin (7) through the back clevis (8) of the hydraulic cylinder (2) and the clevis ring (9) on the reaction plate (3).
7. Place the reaction unit (3 & 4) and the wrench head (1) on the flange in the arrangement shown in the corresponding layout (Figure 5) for the flange. Take note of the number of bolts between the wrench head and the ring of the reaction plate, and between the rings of the reaction plate and reaction leg.
8. Connect the wrench to a power unit using hydraulic hoses. The pressure line of the power unit should be connected to the male quick disconnect of the wrench, while the return line should be connected to the female quick disconnect.
9. Proceed to the operation section of the manual.

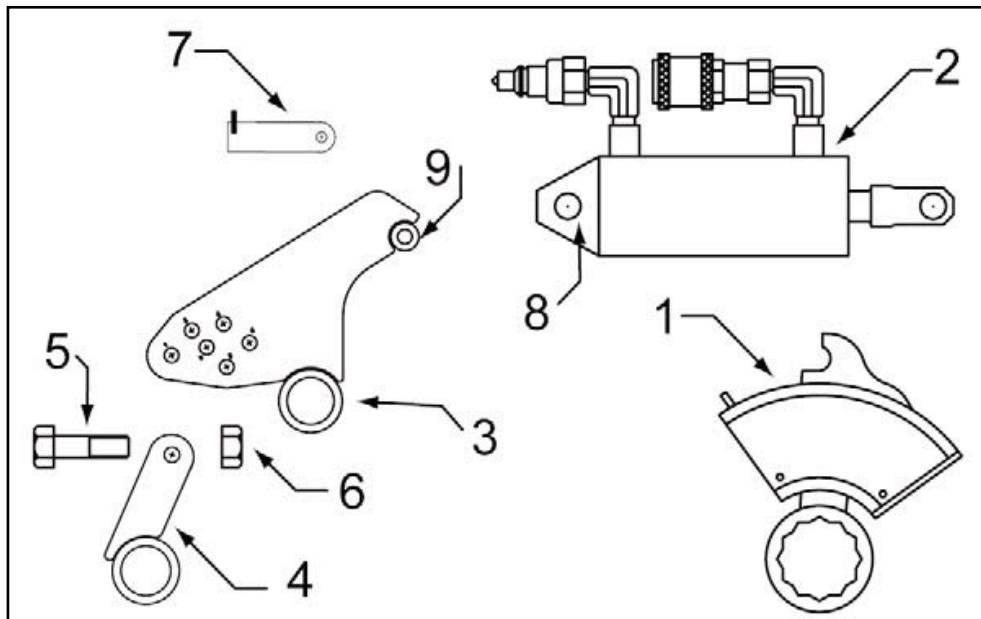

Figure 6

Section 2 - Non-Standard Flanges Assembly

1. Select the correct ThinLINE wrench and reaction unit for the corresponding nut size.
2. Refer to Figure 6 during assembly.
3. Compare the bolt circle diameter and number of bolts in the flange, on which you are working, with the standard flange layouts provided. If you identify a standard which matches your flange, use that set-up.
4. Insert the pin (7) through the back clevis (8) of the hydraulic cylinder (2) and the clevis ring (9) on the reaction plate (3). Refer to Figure 6.
5. Measure the distance (A) of the wrench arm. This distance is 9" on a Series 250-9 (Figure 7).

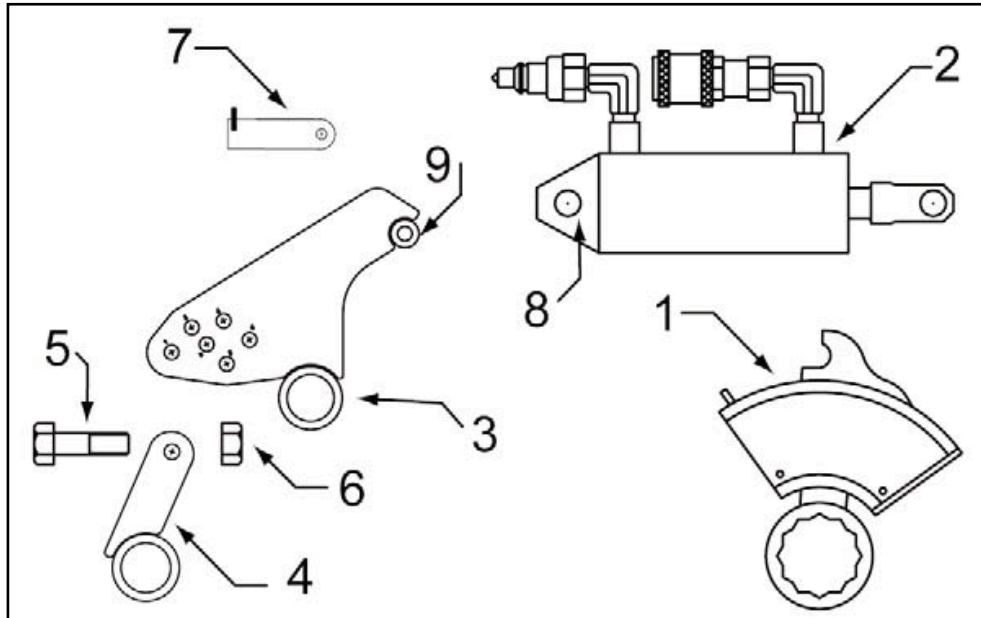

Figure 6

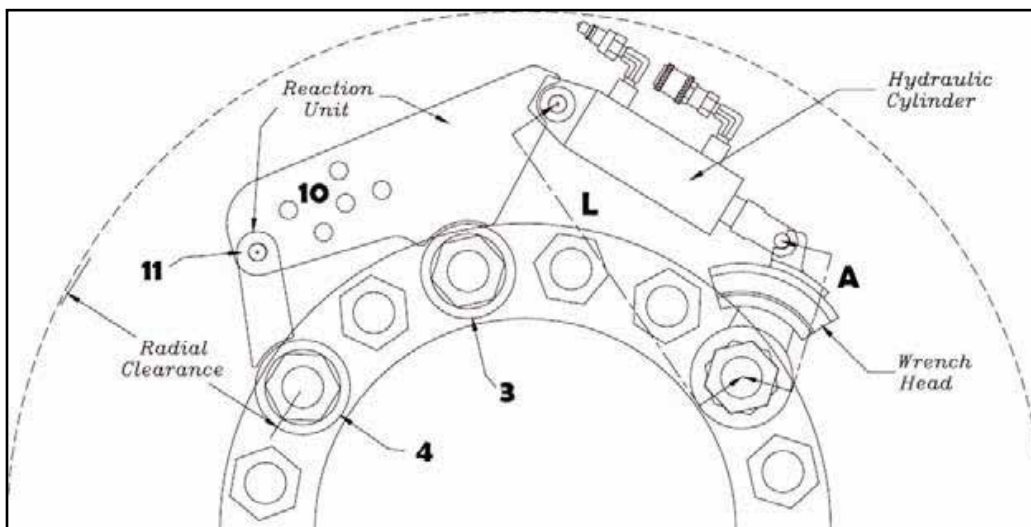

Figure 7

6. When the wrench and reaction unit are properly placed on the flange, the distance (L) from the center of the pin in the back clevis of the cylinder to the center of the bolt being turned should always be 16-5/16" on a Series 250-9.
7. Place the wrench head (1) on any bolt on the flange.
8. Place the ring of the reaction plate (3) around the bolt which would satisfy the following criteria:
 - a. The distance (L) should be correct.
 - b. The wrench head (1) should be able to rotate 60° without interfering with an adjacent bolt.
 - c. The bolt has to turn clockwise when the cylinder extends if tightening, OR counter-clockwise if loosening.
9. Place the ring on the reaction plate (3) around the bolt which would result in the proper set-up.
10. Place the ring of the reaction leg (4) around the bolt which would allow the hole (11) on the leg to align with any hole (10) on the plate. Insert the bolt (5) through the two holes and tighten the nut (6). See Figure 7.

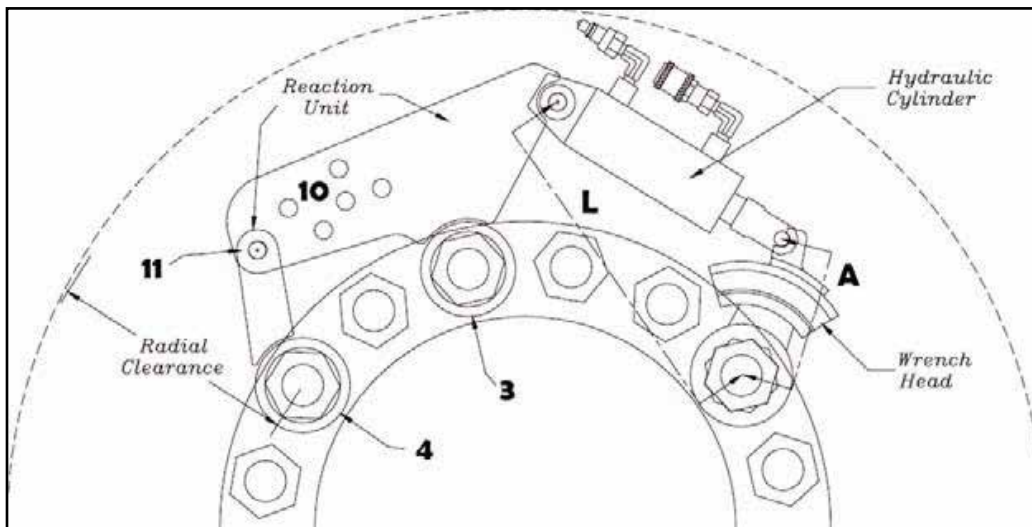

Figure 7

NOTE: If it is impossible to match the hole of the reaction leg with the hole on the reaction plate while keeping the proper set up, mark the reaction plate through the center of the hole in the leg and drill a hole in the plate at that point, equal in diameter to the hole in the leg.

11. Connect the wrench to a power unit using hydraulic hoses. The pressure line of the power unit should be connected to the male quick disconnect, while the return line should be connected to the female quick disconnect.
12. Proceed to the operation section of the manual.

Tightening

1. Select the hydraulic pressure necessary to deliver the required torque from the “Pressure VS Torque” chart. (Page 13)
2. Fully extend the cylinder using the Advance button on the remote control of the hydraulic power unit. Hold the button down while adjusting the pressure control knob on the power unit until the desired reading is shown on the pressure gauge. Retract the cylinder using the Retract button on the remote control.
3. Make sure that all the nuts to be tightened are at least hand tight. Failure to do so will cause the torquing operation to take longer.
4. Raise the pawl in the wrench head using the pawl control lever.
5. Slide the pawl carrier and pawl forward in the wrench head to the first position.
6. Release the pawl control lever to allow the pawl to engage the wrench head.
7. Position the wrench on the first bolt to be tightened using the setup determined previously.
8. Engage the pin in the front clevis of the cylinder in the pawl carrier.
9. Advance and retract the cylinder using the remote control buttons of the hydraulic pump.

NOTE: The pawl and pawl carrier will retract with the cylinder and engage another tooth. Three strokes are required in the 250-9 Series.

10. The pin in the front clevis of the cylinder will pull away from the pawl carrier on the last stroke of a cycle. When this occurs, remove the wrench from the bolt and rotate it backward and repeat steps 4 through 9.
11. Repeat steps 8 through 10 until the cylinder stops advancing. This will occur when the preset pressure (torque) is reached.
12. Repeat steps 4 through 11 for every bolt.

NOTE: It is always recommended to use bolting procedures when tightening bolts. FASTORQ offers bolting technology through its service division. Table 5 on Page 17 contains estimated torque values. For further information call a FASTORQ representative at 281-449-6466 or 800-231-1075.

Loosening

1. Select the hydraulic pressure necessary, to deliver enough torque to break the bolts loose using the “Pressure vs Torque” chart on Page 13.
2. Fully advance the cylinder using the Advance button on the remote control of the hydraulic power unit. Hold the button down while adjusting the pressure control knob on the power unit until the desired reading is shown on the pressure gauge. Retract the cylinder using the Retract button on the remote control.
3. Raise the pawl in the wrench head using the pawl control lever.
4. Slide the pawl carrier and pawl forward in the wrench head to the first position.
5. Release the pawl control lever to allow the pawl to engage the wrench head.
6. Position the wrench on the first bolt to be loosened using the set-up previously determined. The wrench will hold itself as pressure is building up, but it will loosen as pressure is released.
7. Engage the pin in the front clevis of the cylinder in the pawl carrier.
8. Advance and retract the cylinder using the remote control buttons of the hydraulic pump.
9. The pin in the front clevis of the cylinder will pull away from the pawl carrier on the last stroke of a cycle. When this occurs, remove the wrench from the bolt and rotate it backward and repeat steps 3 through 8.
10. Repeat step 9 until the bolt is loose.
11. Repeat steps 3 through 10 for every bolt.

Pressure Vs. Torque Chart			
ThinLINE TLH250-9			
Pressure (psi)	Torque (ft lb)	Pressure (psi)	Torque (ft lb)
100	368	2,900	10,677
200	736	3,000	11,045
300	1,104	3,100	11,413
400	1,473	3,200	11,781
500	1,841	3,300	12,149
600	2,209	3,400	12,517
700	2,577	3,500	12,885
800	2,945	3,600	13,254
900	3,313	3,700	13,622
1,000	3,682	3,800	13,990
1,100	4,050	3,900	14,358
1,200	4,418	4,000	14,726
1,300	4,786	4,100	15,094
1,400	5,154	4,200	15,463
1,500	5,522	4,300	15,831
1,600	2,890	4,400	16,199
1,700	6,259	4,500	16,567
1,800	6,627	4,600	16,935
1,900	6,995	4,700	17,303
2,000	7,363	4,800	17,671
2,100	7,731	4,900	18,040
2,200	8,099	5,000	18,408
2,300	8,468	5,100	18,776
2,400	8,836	5,200	19,144
2,500	9,203	5,300	19,512
2,600	9,572	5,400	19,880
2,700	9,940	5,500	20,248
2,800	10,308		

Table 5

Maximum Suggested Make-up Torque Chart

The following are estimated torque values calculated for B7 studs lubricated with FastLUBE 70+ moly paste loaded up to 50% of yeild strength.

Stud Diameter (in)	Nut A/F (in)	Torque (ft lb)
3/4"	1-1/4"	208
7/8"	1-7/16"	336
1"	1-5/8"	503
1-1/8"	1-13/16"	739
1-1/4"	2"	1,038
1-3/8"	2-13/16"	1,409
1-1/2"	2-3/8"	1,859
1-5/8"	2-9/16"	2,396
1-3/4"	2-3/4"	3,027
1-7/8"	2-15/16"	3,761
2"	3-1/8"	4,604
2-1/4"	3-1/2"	6,650
2-1/2"	3-7/8"	8,348
2-3/4"	4-1/4"	11,215
3"	4-5/8"	14,672
3-1/4"	5"	18,776
3-1/2"	5-3/8"	23,582
3-3/4"	5-3/4"	29,144
4"	6-1/8"	35,519

Table 6

Troubleshooting

Problem	Possible Causes	Possible Solutions
The Cylinder does not extend or retract	The quick disconnects are not connected properly	Check connections
The quick disconnect will not lock, or will not release	The hydraulic hose is still pressurized	Release the pressure in the hose
The wrench locks up on the bolt	The pawl control lever is jammed	Release the pawl control lever

Table 7

Storage

When storing ThinLINE, follow these steps:

1. Fully retract the cylinder.
2. Rinse and clean the wrench.
3. Lubricate the entire wrench with a light film of oil.

ThinLINE Wrench Models

ThinLINE wrenches include a wide variety of wrench sizes to fit different applications. These wrenches are available in six series, and operate on 5,500 psi of hydraulic pressure. The table below lists the series with their corresponding range of nut sizes and torque capacity.

ThinLINE		
Series	Nut Sizes A/F (in)	Torque (ft lb)
150-4	1-1/4" to 2"	3,240
200-6	2-3/16" to 3-1/8"	8,640
250-9	3-1/2" to 4-5/8"	20,250
325-12	4-1/4" to 5-3/8"	41,840

Table 8



Warranty

All **ThinLINE** models are covered by the FASTORQ NO B.S. Lifetime Guarantee Program. It's as simple as the name implies: any product covered by our No B.S. Lifetime Guarantee is covered for life. Period. Warranty includes seal replacement on cylinders.

The "fine print"

All products manufactured by Fastorq are warranted against defects of material or workmanship for the period defined by product line/model from the date shipped when these products are used within the service, specification and pressure range for which they were designed and manufactured. Warranty programs vary in length of time of coverage by product line.

All products are potentially eligible for the Warranty Extension Program. Warranty programs are for customers in the U.S. and Canada but may be extended to customers in other countries under certain circumstances. Customers must complete online or mail-in product registration. Warranties do not cover loss or theft, abuse, misuse, overloading or alteration of product or components. Freight costs to deliver product to FASTORQ is the customer's responsibility; FASTORQ pays for the return shipping costs on warranty repairs/replacements. Repair or replacement will be determined by FASTORQ technicians.

Warranties are limited to repair or replacement of parts found by FASTORQ to be defective in material or workmanship and does not extend to claims for labor, expense, or other loss or damage occasioned by such defect of material or workmanship. No unauthorized back charges will be accepted. Warranties do not cover deterioration by corrosion, erosion, or any cause of failure other than defect of material or workmanship. Purchasers are expected to determine the suitability of FASTORQ products of their particular purposes. No other warranty, expressed or implied, will be allowed without the written agreement of FASTORQ. Any adjustments to this warranty must first be approved in writing by FASTORQ.